

ADKINS

ADKINS
HEAT PRESS TECHNOLOGY

STUDIO CLAM 38



Operators Handbook

All products within the ADKINS range are labelled with CE marking and are manufactured and tested to comply with EC safety regulations.

©Charterhouse Holdings PLC. All rights reserved.

Preface

Dear User

Welcome to the growing group of Studio Clam 38 Press users. The product you have purchased has been carefully designed and manufactured to ensure that you, the user, will gain the maximum benefit.

All Charterhouse Holdings PLC products are specifically designed to ensure ease of use with particular attention to safety requirements.

Should you discover any fault or damage upon receipt of this product, you should immediately contact your supplier.

Contents

1.	Introduction Studio Clam 38 Press	1
1.1	Specifications of the Studio Clam 38 Press	1
1.2	Safety	2
2.	Installation	3
2.1	Transport instructions	3
2.2	Installing the machine	3
2.3	Electrical requirements	3
2.4	Adjusting the pressure	4
3.	How to operate the Studio Clam 38 Press	5
3.1	Starting with the Studio Clam 38 Press	5
3.2	Working with heat transfer materials	5
3.3	Pressing pad assembly	6
3.4	Shutting down the machine	6
4.	Maintenance of the Machine	7
4.1	Daily maintenance	7
4.2	Periodic maintenance	7
4.3	Cleaning	7
5.	Machine Drawings and Diagrams	8
5.1	General Layout	9
5.2	Exploded diagram and parts list	10
5.3	Control unit operation	11
5.4	General electrical diagram	12
5.5	Detailed electrical diagram	13
6.	Design Change	14
7.	Guarantee (Limited Warranty)	15
	Declaration of Conformity	16

1. Introduction Studio Clam 38 Press

1.1 Specifications of the Studio Clam 38 Press

The Studio Clam 38 Press is a manually operated heat press for transfer printing and material fusing. It is ideal for medium volume production.

The work area is: 38 cm x 38 cm (*15 x 15 in*).

Specifications

Power consumption	2.2 kW
Power supply	230 Volts AC
Working temperature	0 - 230°C (32 - 446 °F)
Display timer range	1 – 9999 sec
Machine height open	86 cm (33.8 in)
Machine height closed	34.5 cm (13.6 in)
Machine width	38 cm (15 in)
Machine depth	61 cm (24 in)
Working area	40(W) x 87(H) x 69(D) cm (15.7(W) x 34.25(H) x 27(D) in)
Net weight	30.7 Kg (68.3 lbs.)
Gross weight	34 Kg (75 lbs.)
Press pad dimensions	38 cm x 38 cm (15 x 15 in)
Mains Fuse	15 A
Auxiliary Fuse	2 A

1.2 Safety Tips

- ◆ **If required, our customer service team** can arrange maintenance service.
 - ◆ **The Studio Clam 38 Press** meets the European Legislation standard. Under normal conditions accidents are rare. However listed below are some practical points to ensure your safety.
 - **Always use both hands** when opening or closing the press for positive control of the movement of the handle.
 - **Always switch off** the current (and pull plug out of the socket) when undertaking maintenance work or when cleaning the machine.
 - **Ensure that there is** sufficient space around the machine. Cables and connections must not get jammed. Although the heat radiation of the press is low, there should be enough space for cooling down.
 - **Avoid contact** with the heat plate.
 - ◆ **DO NOT REMOVE THE INSTRUMENT COVER UNLESS QUALIFIED TO DO SO** - touching internal parts is dangerous and may cause shock hazard. All electrical connections inside covers are live. Never operate Press with any covers and/or guards removed.
 - ◆ **PROTECT THE MAINS CABLE** - damage to the mains cable may cause fire or shock hazard. When unplugging, hold by the plug only and remove carefully. Take care that the mains cable does not come into contact with the heat plate (or moving parts of the mechanism) during operation of the machine.
 - ◆ **OPERATING AMBIENT TEMPERATURE RANGE** - the operating ambient temperature range is 0°C - 35°C, (32°F - 104°F) and humidity of 20 - 80%.
 - ◆ **MACHINE FUSES** - type: ultra-rapid (FF) fuses 1¼" 240 Vac max. 15 Amps.
 - ◆ **WARNING - THIS APPARATUS MUST BE EARTHED (GROUNDED)**
 - ◆ **CAUTION**
This machine gets hot whilst operating. Take care not to touch any surfaces that are labelled "Caution this plate is HOT".
 - ◆ **MACHINE OPERATION**
Only persons trained to do so should operate this machine.
-

2. Installation

2.1 Transport instructions

The machine comes to you either shrink-wrapped or in a box. If you have to transport the machine at any time it is recommended that you use a similar box and packing method. Please let the machine cool down and lower the handle to the locked position.

2.2 Installing the machine

- 2.2.1 **Remove all** packaging from the heat press.
- 2.2.2 **Check to ensure** that no damage has been caused to the machine during transit.
- 2.2.3 **Place the machine** on a sturdy horizontal surface that is within easy reach of the operator and allow space for the handle to move up to the loading position. Ensure that no items vulnerable to heat radiation are too close to the machine.

2.3 Electrical requirements

The Studio Clam 38 Press should be connected to the mains supply, (nominally 230VAC for the European Market) by the mains cable provided and a suitable plug.

The press is designed for 230VAC 50/60 hertz and requires exclusive use of a power outlet rated for at least 15 Amps.

Ensure that the supply rating on the machine specification plate corresponds with your local supply and that the correct plug is fitted (Europe).

MAINS LEAD

The wires in this mains lead are coloured in accordance with the following code:

Green and Yellow:	}	EARTH
Blue:		NEUTRAL
Brown:		LIVE

As the colours of the wires in the mains lead of this apparatus may not correspond with the coloured markings identifying the terminals in your plug, proceed as follows:-

Electrical requirements (cont.)

1. **The wire coloured green and yellow** must be connected to the terminal in the plug that is marked by the letter E, or by the safety earth symbol coloured green, or green and yellow.
2. **The wire coloured blue** must be connected to the terminal, which is marked with the letter N.
3. **The wire coloured brown** must be connected to the terminal, which is marked with the letter L.

NOTE:

Replacement of the mains cable must be done by a competent service engineer.

HEATING ELEMENT

The heating element fitted to the **Studio Clam 38 Press** is rated at 2.2 kW

Never connect to any outlet or power supply having a different voltage/frequency from that on the machine data plate.

2.4 Adjusting the pressure

This press is fitted with a pressure-adjusting unit, which enables the heat plate assembly to be raised or lowered by use of a pressure adjustment knob located on the top of the heat plate:

- a) **To increase pressure** or to use thinner materials turn knob clockwise.
- b) **To decrease pressure** or to raise the heat plate assembly to enable thicker materials to be used, turn the adjustment knob anticlockwise.

NOTE

DO NOT adjust the pressure when the machine is clamped shut

CAUTION

This machine is designed to be used with a light to medium clamping pressure. If the pressure of the machine is adjusted too high this may cause damage to the machine and invalidate your warranty. Other machines are available for high-pressure applications. Please ask your supplier for details.

3. How to Operate the Studio Clam 38 Press

3.1 Starting with the Studio Clam 38 Press

3.1.1 Plug into your supply outlet and switch supply on.

N.B. Please ensure the mains plug is easily accessible to the operator so that in the event of a fault the machine can be unplugged.

3.1.2 Turn on the Studio Clam 38 Press; the on/off switch is on the side of the machine. Set the machine controls as necessary. See instructions for adjusting the pressure, **page 4** and operation of Control Units **page 11**. Press the red on/off button to activate and heat the Heat Plate.

3.2 Working with Heat Transfer Materials

Always ascertain from the supplier of material and transfer paper, that the material to be used is suitable for, and has been prepared for transfer printing.

3.2.1 Close the press to check the amount of closing pressure the machine has been set at. If more or less pressure is required then open the machine and turn the pressure-adjusting knob located on top of the heat plate. For further instructions see “pressure adjustment”.

3.2.2 Ensure that the heat controller is set to the correct setting for the material being used. Before using the machine, preheat the base pad of the machine by closing and re-opening the press a number of times.

After pre-heating ensure that the machine is in the fully open position.

3.2.3 Place the article to be transfer printed onto the pressing pad and locate the transfer paper/substrate material on top in the position required. **Take care not to touch the heat plate to avoid the risk of a burn.**

3.2.4 Lower the heat plate by pulling down the handle.

3.2.5 When the required time interval has elapsed the alarm will sound and the press should be opened by lifting the handle up until it locks into position.

Unload the garment from the table of the machine taking care not to touch the heat plate to avoid risk of a burn.

3.3 Pressing Pad Assembly

The pressing pad normally supplied with this machine is silicone rubber. The pressing pad must be maintained in good condition at all times and replaced when showing signs of wear. A worn pressing pad will always affect the quality of printing/fusing. Do not insert items into the machine, which would tend to cut the pressing pad, i.e. buttons, pins, press-studs or zips.

Never allow the hot heat plate to rest on the pressing pad when the press is not being used as the pad may be damaged.

IMPORTANT NOTE:

The pressing pad supplied with the machine is of the correct thickness. Using a thicker pad may invalidate your warranty.

3.4 Shutting Down the Machine

To shut down the machine, turn off the on/off switch at the side of the machine. The handle should be in the up position.

4. Maintenance of the Machine

4.1 Daily Maintenance

For good press results it is important to keep the press surfaces clean. Wipe the surface of the heat plate with a dry cloth before use when the plate is cold.

4.2 Periodic Maintenance

Put a few drops of oil onto the various pivot pins and the pressure adjusting screw every three months.

4.3 Cleaning

Clean the outside of the machine frequently with a clean, moist cloth. This may conveniently be carried out before starting when the machine is **cool**. First unplug the machine!

5. Machine Drawings and Diagrams

On the following pages are the schematic diagrams for the Studio Clam 38 Press.

- 5.1 General Layout..... Page 9**
- 5.2 Exploded diagram and parts list..... Page 10**
- 5.3 Control unit operation..... Page 11**
- 5.4 General electrical diagram..... Page 12**
- 5.5 Detailed electrical diagram..... Page 13**

5.1 Machine General Layout

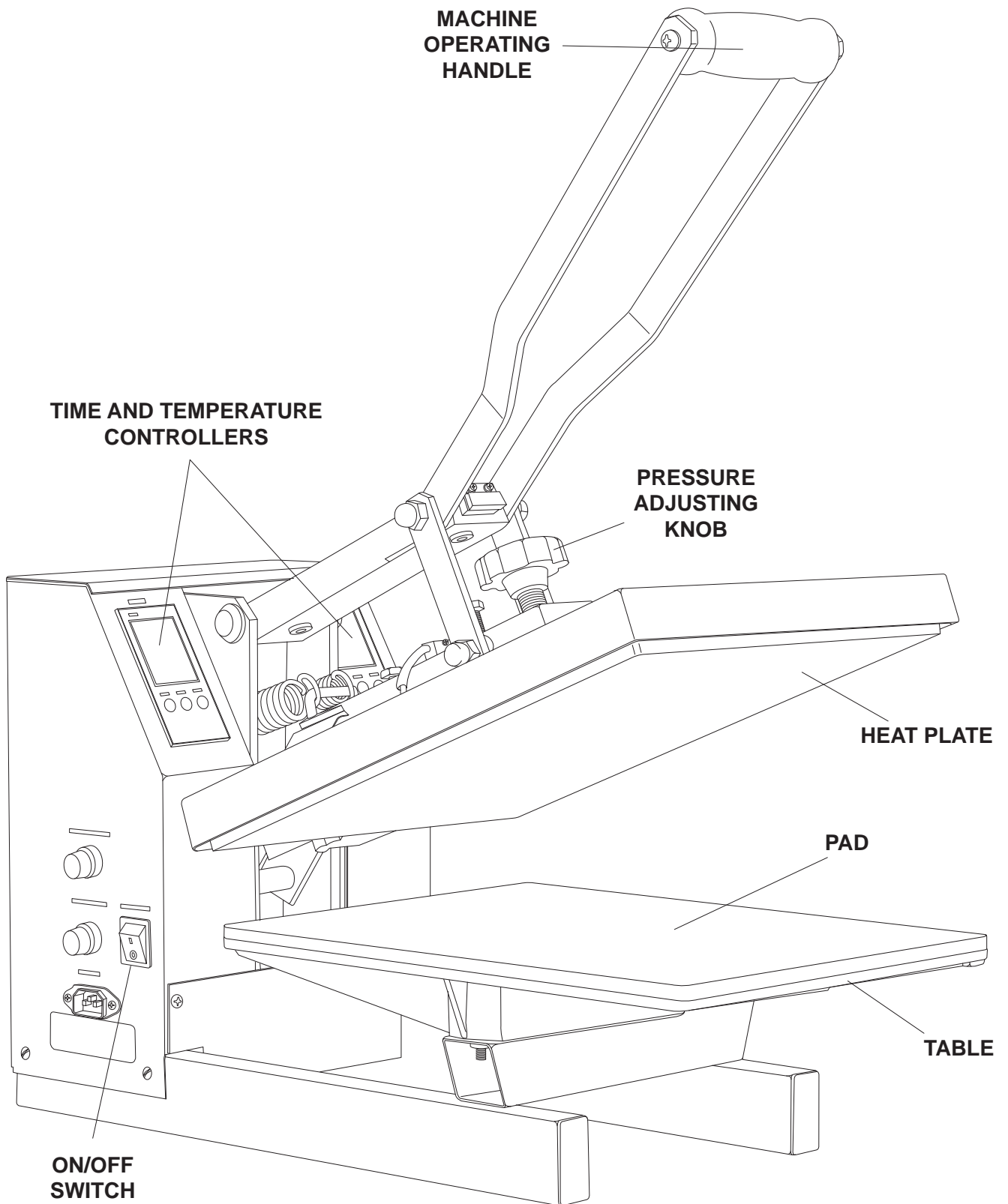

5.2 Exploded Diagram and Parts List

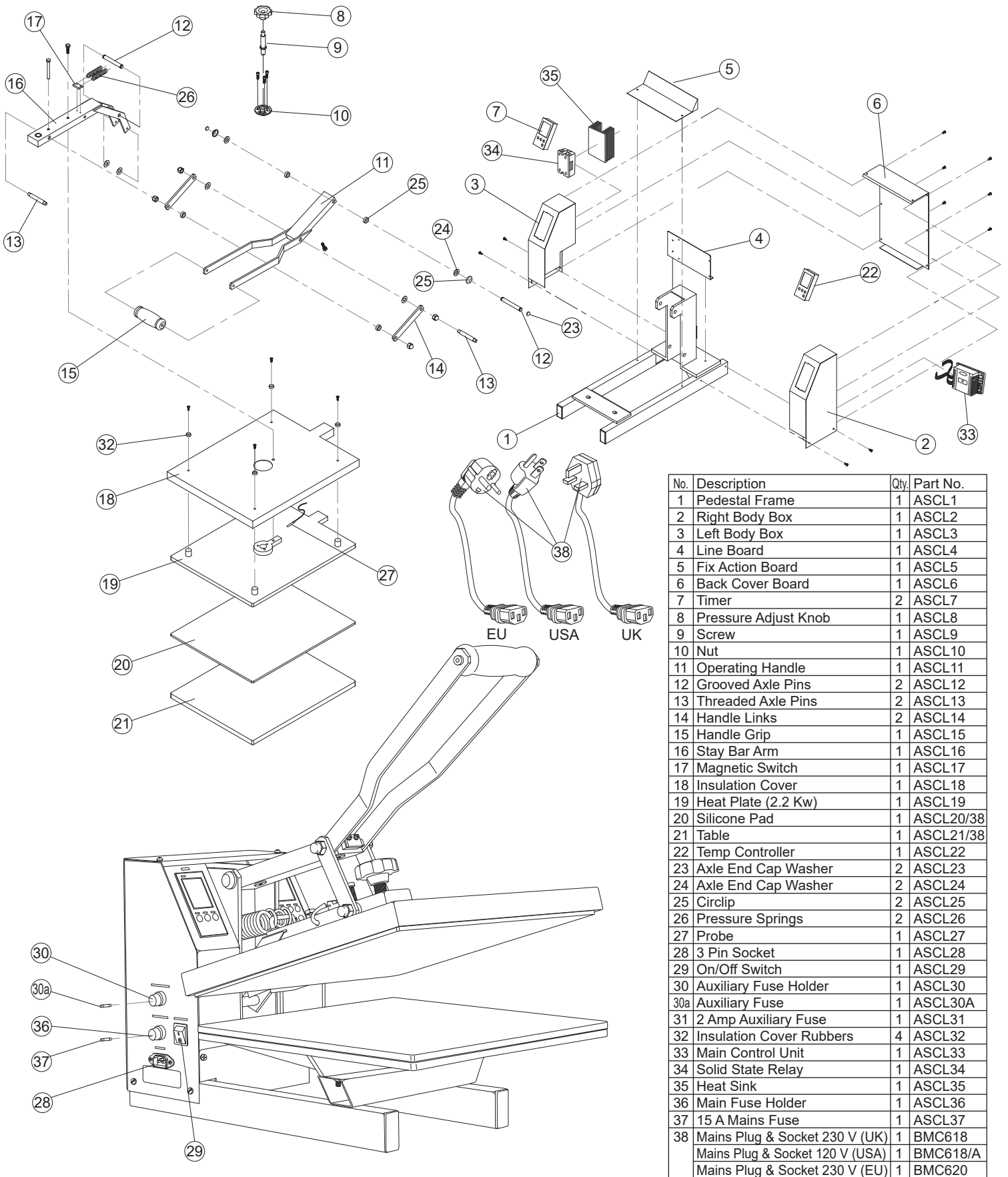

5.3 Operation Of Control Units, Setting Temperature and Time

(The press must always be in the open position before the controller is set)



Setting Temperature

1. Switch on machine.
2. Press 'UP' and 'DOWN' buttons to change temperature values.
3. The unit stores automatically once required value is achieved.
4. Press 'START/STOP' button to start machine heating.



Setting Time

1. Switch on machine.
2. Press 'UP' and 'DOWN' buttons to change time values.
3. The unit stores automatically once required value is achieved.
4. Press 'START/STOP' button to start machine.

Setting Digital Counter to Zero

1. Press 'CLEAR' button and 'COR' will appear in controller window and 'COUNTER' value will flash.
2. Press 'CLEAR' button again to zero counter.

5.4 General Electrical Diagram

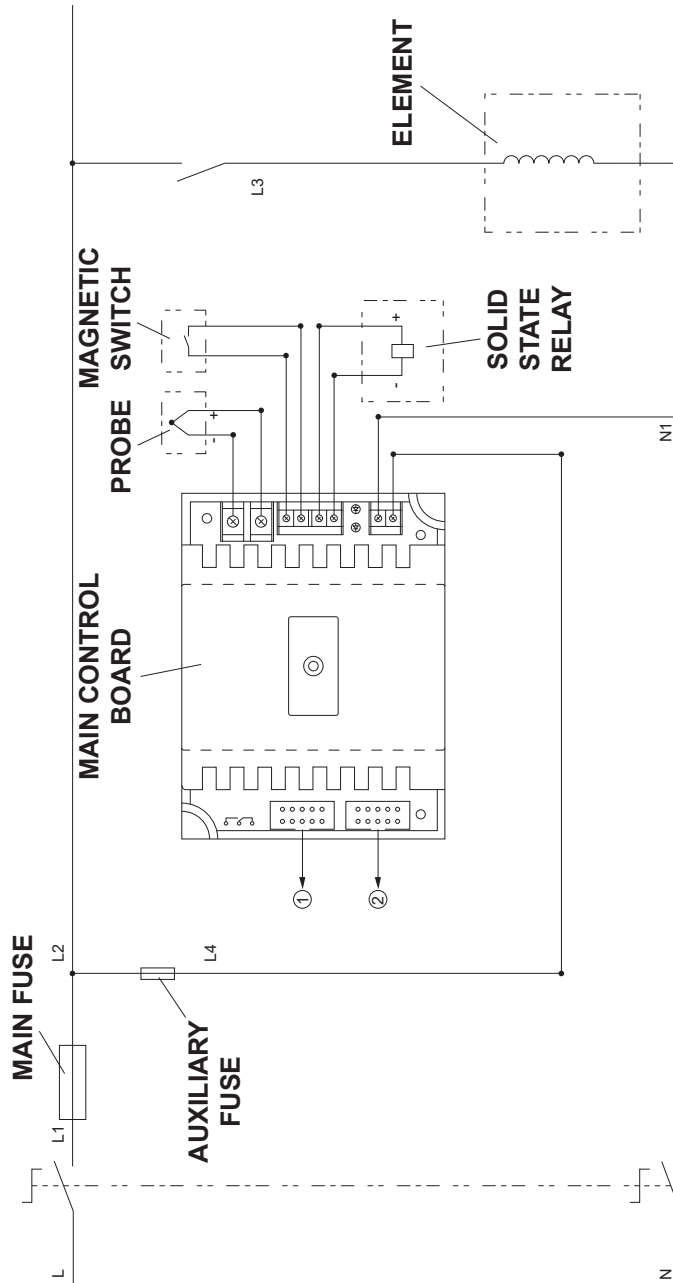

KEY:

- ① TEMPERATURE CONTROL PANEL
- ② TIME CONTROL PANEL

5.5 Detailed Electrical Diagram

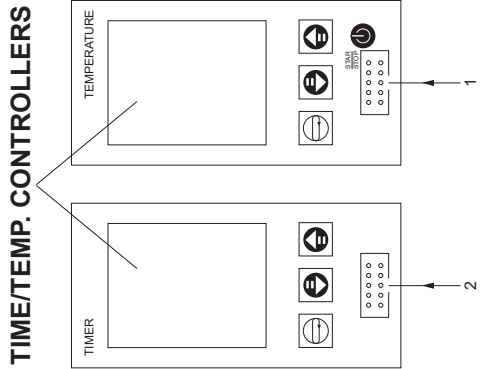
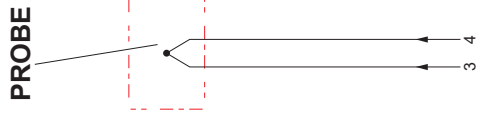
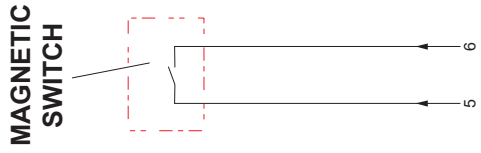
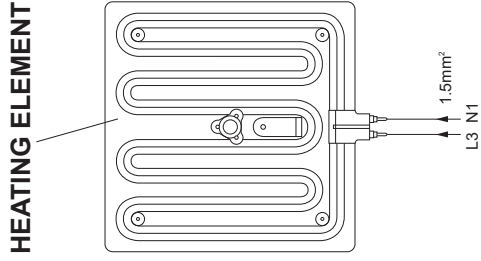

CONNECTION LINE OF LEFT MACHINE BOX

SOLID STATE RELAY

MAIN CONTROL BOARD

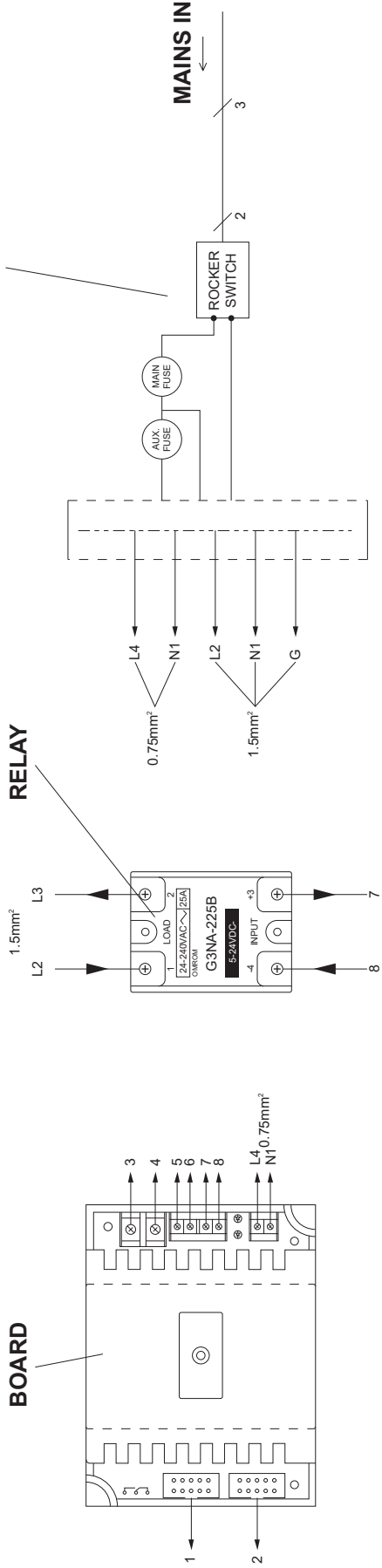

6. Design Change

With the policy of constant improvement and/or modification to meet changing conditions, the right is reserved to change the design and/or specifications at any time without prior notification, and therefore specifications may vary and not be in accordance with this manual.

7. Guarantee (Limited Warranty)

Charterhouse Holdings PLC warrants that the press is free from defects in material and workmanship for a period of 12 months from the date of supply to the customer. The machine comes with a one-year warranty on parts and 90 days labour.

This warranty covers all parts to repair the defects, except when damage results from misuse or abuse, accident, alteration or negligence or when a machine has been improperly installed.

If a press covered by warranty should need to be returned to the factory for examination and repair, if on-site component replacement is not possible, Charterhouse Holdings PLC will make every effort to repair the customers press. The warranty will only be effective when Charterhouse Holdings PLC authorises the original purchaser to return the machine to the factory and only when the product upon examination has proven to be defective.

Should in our opinion any part of this press be defective in materials or workmanship, it will be replaced or repaired free of charge, provided that the press has been installed and operated in the correct manner and not subjected to misuse. If Charterhouse Holdings PLC authorise a replacement press, the warranty of the replacement press shall expire on the anniversary date of the original machines invoice to the customer.

In order for this warranty to be effective, no return of machine or parts may be made without prior factory authorisation. (This will exclude any travelling and/or carriage costs which will be charged at our discretion).

This is the sole warranty given by the company; there are no warranties, which extend beyond the description on the face hereof. The seller disclaims any implied warranty of merchantability and/or any implied warranty of fitness for a particular purpose; the buyer agrees that the goods are sold "as is". Charterhouse Holdings PLC does not warrant that the functions of the press will meet the customer's requirements or expectations. The entire risk as to use, quality and performance of the press lies with the customer. (No claim of any kind shall be greater than the sale price of the product or part to which the claim is made).

In no event will Charterhouse Holdings PLC be liable for any injury, loss or damage, including loss of profits, destruction of goods or any special, incidental, consequential or indirect damages arising from the use of the press or accompanying materials. This limitation will apply even if Charterhouse Holdings PLC or its authorised agent had been advised of the possibility of such damage.

A. ADKINS & SONS LIMITED
DECLARATION OF CONFORMITY



<p>Application of Council Directives:</p> <p>Standards to which Conformity is Declared:</p>	<p>Machinery, Low Voltage. E.M.C.</p> <p><u>BS EN ISO 12100:2010</u> - Safety of machinery: Basic Technology, Principles of Design. <u>BS EN 60204-1:2006+A1:2009</u> - Safety of machinery: Electrical Equipment of Machines <u>BS EN 60529:1992-A2:2013</u> - Degree of protection provided by enclosures. <u>BS EN ISO 13850:2015</u> - Safety of Machinery: Emergency Stops. <u>BS EN ISO 141211:2007</u> - Safety of Machinery: Principles for Risk Assessment. <u>BS EN 55011:2016+A1:2017</u> - Class A Group 2 Equipment - EMC Emissions. <u>BS EN ISO 61000-6-4:2007+A1:2011</u> - EMC Conducted Emissions. <u>BS EN ISO 61000-6-2:2005</u> - EMC Immunity. <u>Low Voltage Directive 2014/35/EC</u> - Including DIN EN 61557-1, -4 and -5. <u>Electro Magnetic Interference Directive 2014/30/EC</u> - Including DIN EN 61000-6 series of standards.</p>
<p>Manufacturer's Name:</p> <p>Manufacturer's Address:</p>	<p><u>A. Adkins & Sons Limited</u></p> <p>High Cross, 18 Lancaster Road, Hinckley, Leicester, LE10 0AW, United Kingdom.</p>
<p>Type of Equipment:</p>	<p>Studio Clam 38 Heat Press</p>
<p>Standards Compliance:</p>	
<p>Model Number:</p>	<p>.....</p>
<p>Serial Number:</p>	<p>.....</p>
<p>Year of Manufacture:</p>	<p>.....</p>

I, the undersigned, hereby declare that the equipment specified above conforms to the above directives and standards.

Place: Hinckley, United Kingdom

Signature: 

Date:

Full Name: Marie McMahon
 Position: General Manager