



**ADKINS**  
HEAT PRESS TECHNOLOGY

## ALPHA INDUSTRIAL FLATBED SERIES 7 (100 CM x 120 CM)



## Operators Handbook

All products within the ADKINS range are labelled with CE marking and are manufactured and tested to comply with EC safety regulations.

# Preface

---

Dear User

**Welcome to the growing group** of Alpha Industrial Flatbed Series 7 Transfer Press users. The product you have purchased has been carefully designed and manufactured to ensure that you, the user, will gain the maximum benefit.

**All Charterhouse Holdings PLC products** are specifically designed to ensure ease of use with particular attention to safety requirements.

Should you discover any fault or damage upon receipt of this product, you should immediately contact your local supplier.

---

# Contents

---

<b>1.</b>	<b>Introduction Alpha Industrial Flatbed Series 7 Transfer Press</b>	<b>1</b>
1.1	Application	2
1.2	Features	2
1.3	Specifications of the Alpha Industrial Flatbed Series 7 Transfer Press	3
<b>2.</b>	<b>Installation</b>	<b>5</b>
2.1	Step-by-step installation procedure	5
<b>3.</b>	<b>Maintenance and troubleshooting</b>	<b>9</b>
3.1	Daily maintenance	9
3.2	Weekly maintenance	9
3.3	Cleaning	9
3.4	General maintenance	9
3.5	Troubleshooting	10
3.6	Heat Plate Temperature Measurement	11
<b>4.</b>	<b>Machine drawings and diagrams</b>	<b>12</b>
4.1	General layout	13
4.2	PLC controller operation procedure	14
4.3	Exploded diagrams and parts list	16
4.4	Electrical diagram	19
4.5	Pneumatic diagram	20
<b>5.</b>	<b>Design change</b>	<b>21</b>
<b>6.</b>	<b>Guarantee (limited warranty)</b>	<b>22</b>
	<b>Declaration of conformity</b>	<b>23</b>

---

# 1. Introduction Alpha Industrial Flatbed Series 7 Transfer Press

---

**The Alpha Industrial Flatbed Series 10 Transfer Press** is a pneumatically operated heat press for transfer printing and material fusing and comes supplied in a dual reciprocating table configuration making it ideal for high volume production with low operator fatigue.

The dual fusing areas for the **Alpha Industrial Flatbed Series 7 Transfer Press** is:

- 100 cm x 120 cm

**The Alpha Industrial Flatbed Series 7 Transfer Press** is operated such that in the normal 'stand by mode', the heat plate is retained in the elevated position by compressed air, applied to the appropriate ports of the acting cylinder.

Pressing either of the green buttons on the control boxes (located on either side of the frame) will initiate an automatic pressing cycle. This is only possible when the sliding table is positioned correctly to align the work under the heat plate, at which time the guard flap is manually closed. Micro switches then detect the closure of the flap and apply power to the pneumatic driver board. The pneumatic driver board then applies power to the intermediate relay, which in turn provides power to both the pneumatic solenoid valve and the digital timer, which allows the solenoid valve to open the intake door. Air is then applied to the other cylinder ports, forcing the heat plate onto the table and initiating the automatic pressing sequence.

**After expiry of the pre-set time the digital controller** sends a signal to the pneumatic driver board, the driver board then cuts the power for the downstream line, deactivating the solenoid valve, which in turn closes the intake door. The cylinder then returns the heat plate to its elevated position.

**The Alpha Industrial Flatbed Series 7 Transfer Press** is produced nominally as 380 - 440 Volts AC - 3 phase (neutral + earth).

## 1.1 Application

---

This machine is suitable for Textile, Leather, Metal, Ceramic, Glass and Organic glass transfer, with colourful transfer images and rich layers.

## 1.2 Features

---

- 1. This machine employs advanced electronic control technology:**
  - Dual pressure plates take turns to work automatically.
  - Very accurate safety limit switch.
  - Higher reliability.
  - Longer service life.
- 2. PLC controller (programmable logic controller):**
  - Higher control precision.
  - Extremely stable in operation.
  - Large PLC screen displaying all data clearly.
- 3. Heat platen uses newly developed pluggable heat elements:**
  - The heat is more evenly spread, and the temperature is more balanced and stable.
  - If one of the heating tubes is faulty during usage, the customer can replace them individually instead of having to replacing the entire heating element, thereby saving costs.
- 4. Dual air cylinders:**
  - Creates higher, more uniform pressure, allowing the transfer range to be much wider.
- 5. Installation and calibration is convenient and fast:**
  - Easy to maintain and clean.

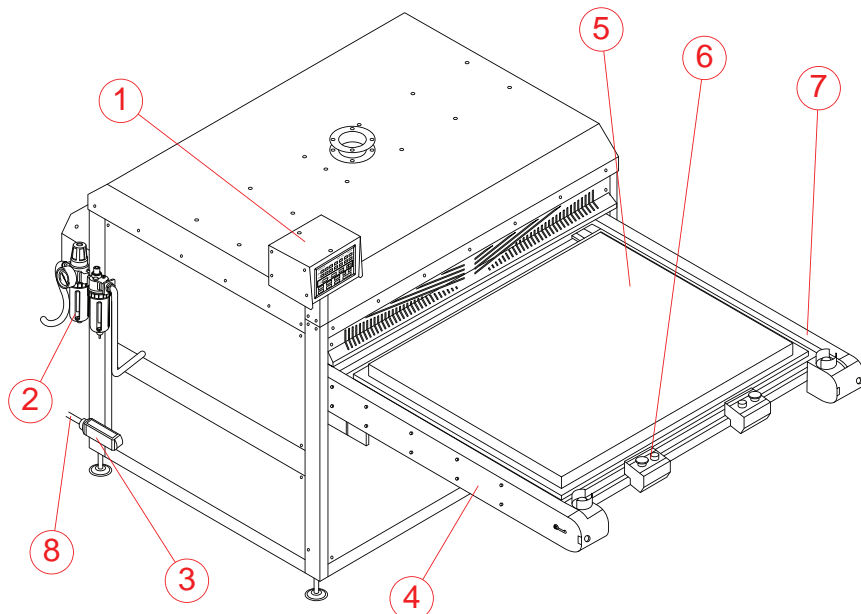

1. PLC control box	3. Over wire Explosion proof box	5. Upper and lower tray	7. Emergency stop button
2. Air filter	4. Left and right supporting arms	6. Green start button	8. Power cable

### 1.3 Specifications of the Alpha Industrial Flatbed Series 7 Transfer Press

---

Below is a list of the specifications of the **Alpha Industrial Flatbed Series 7 Transfer Press**:

<b><u>Specifications</u></b>	<b>(100 cm x 120 cm - table size)</b>
Power consumption	9 kW
Power supply	380 - 440 Volts AC (3-Phase) N+E
Working temperature	70 - 225°C
Display timer range	0 - 999 sec
Suggested compressed air supply	5 bar
Maximum compressed air supply	6 bar
Machine height	155 cm
Machine width	165.8 cm
Machine depth	271.7 cm
Working area	170.1(W) x 152.2(H) x 271.7(D) cm
Gross weight	1004 Kg
Net weight	782 Kg
Press pad dimensions (x2)	100 cm x 120 cm
Fuse(s)	34 A
A-weighted noise level	<70 dB(A)

## Specifications of the Alpha Industrial Flatbed Series 7 (Cont.)

---

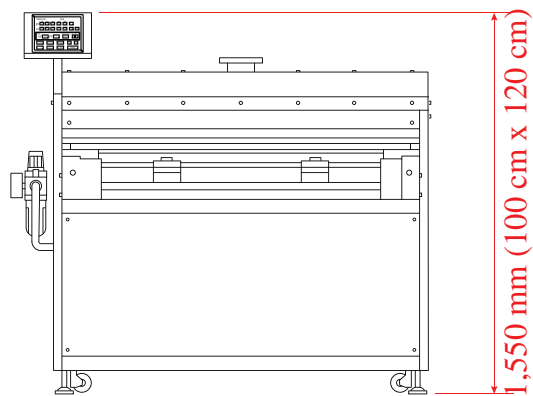
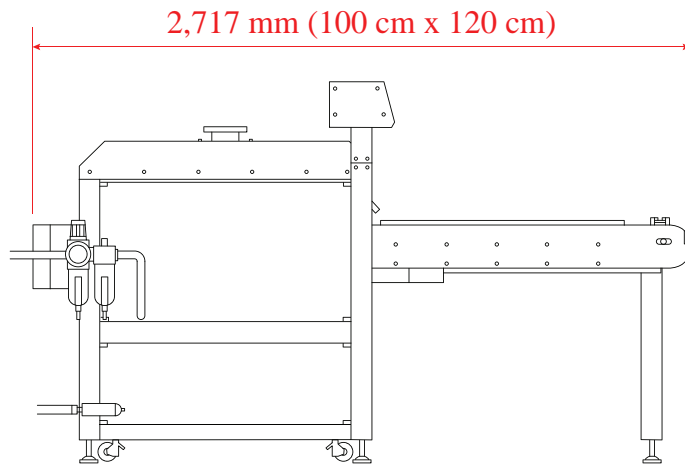
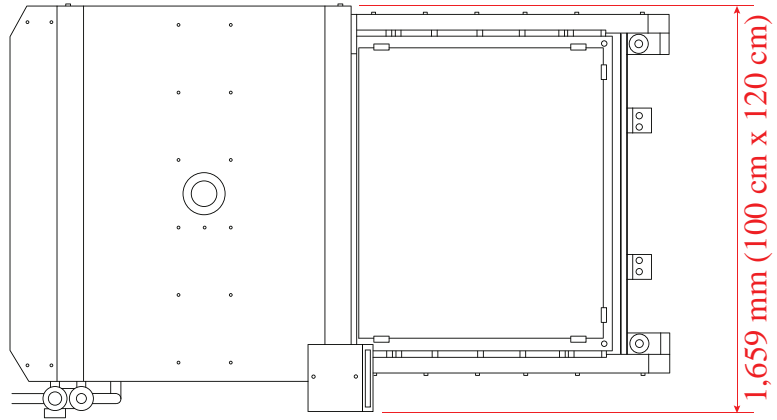

## 2. Installation

---

### 1.2 Step-by-step installation procedure

---

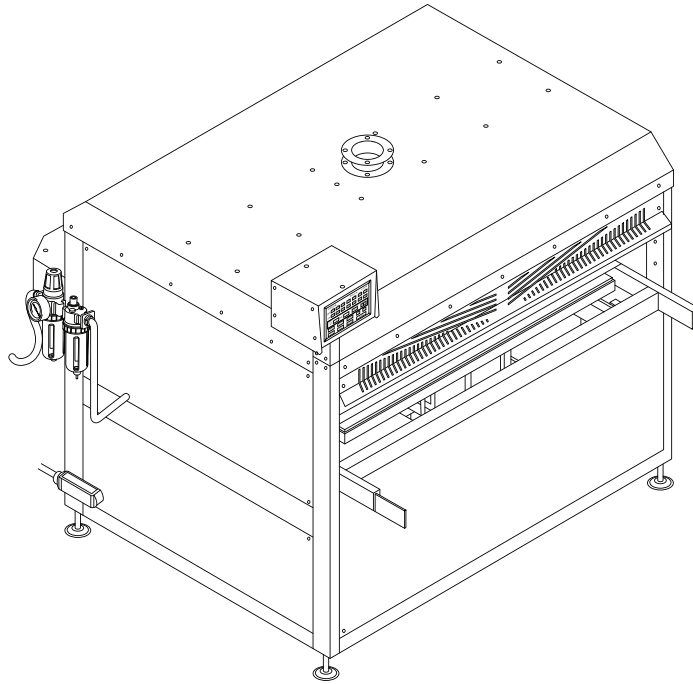

**1.2.1** Open the crate, the machine is as shown above.

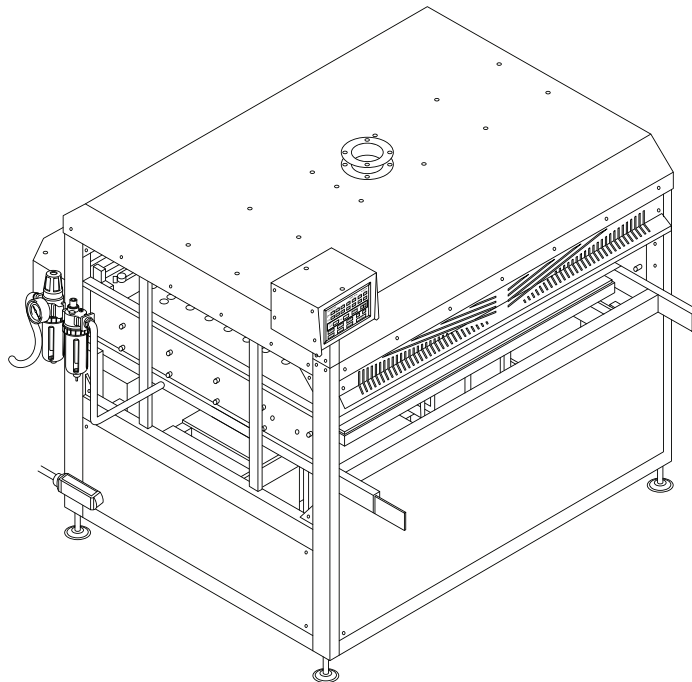

**1.2.2** Check and make sure that no part of the machine is missing or has been damaged during the shipping process. Demount the left and right upper panels [see above].

## Installation (Cont.)

---

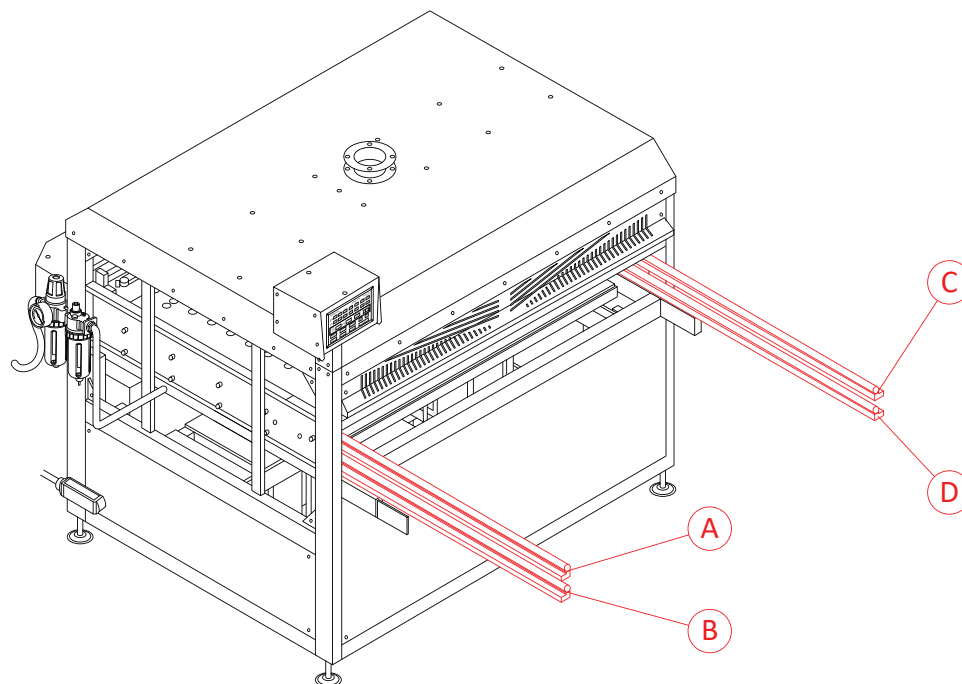

**1.2.3 Install the slide tracks.** Fix **A**, **B**, **C** and **D** slide tracks to the machine frame [see above], fixing the screws hand-tight only.

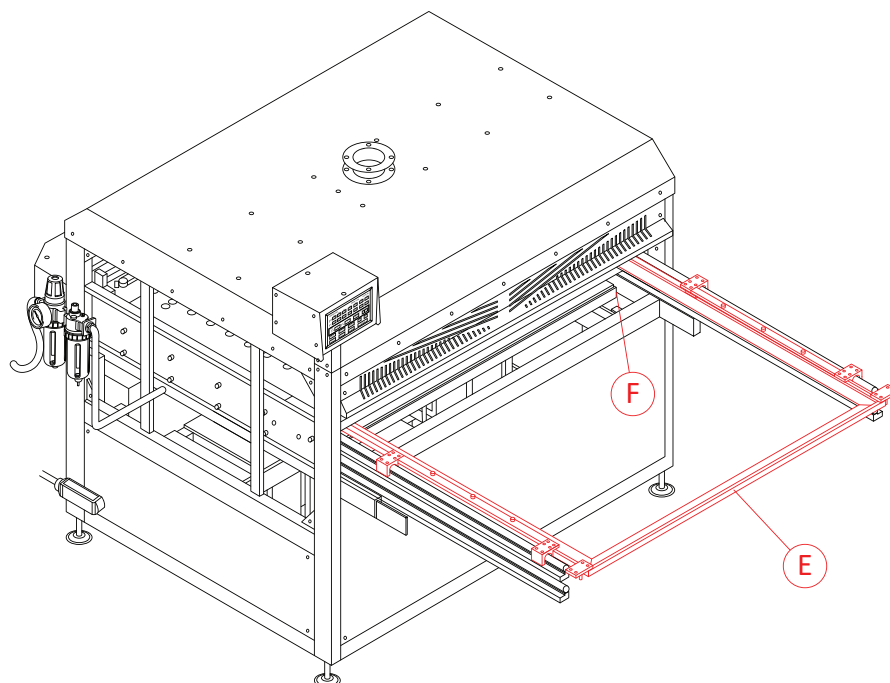

**1.2.4 Fix the slide tracks onto the machine.** Installing the sliding frame **E** and **F** to the slide tracks [see above].

## Installation (Cont.)

---

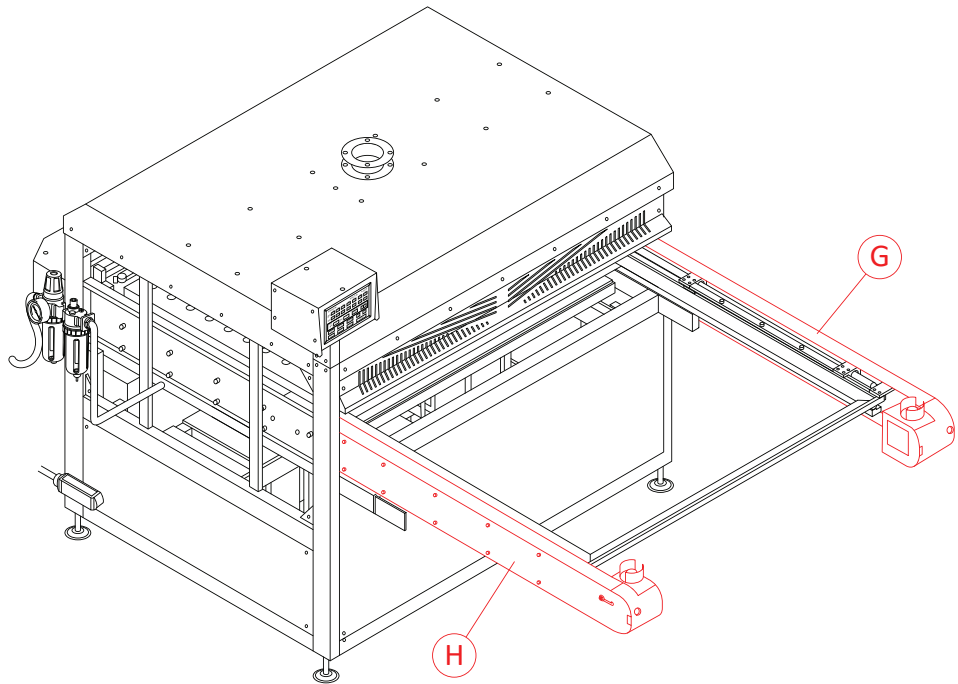

**1.2.5 Install the left front plate of slide track H and right front plate of slide track G [see above], locking the screws tightly.**

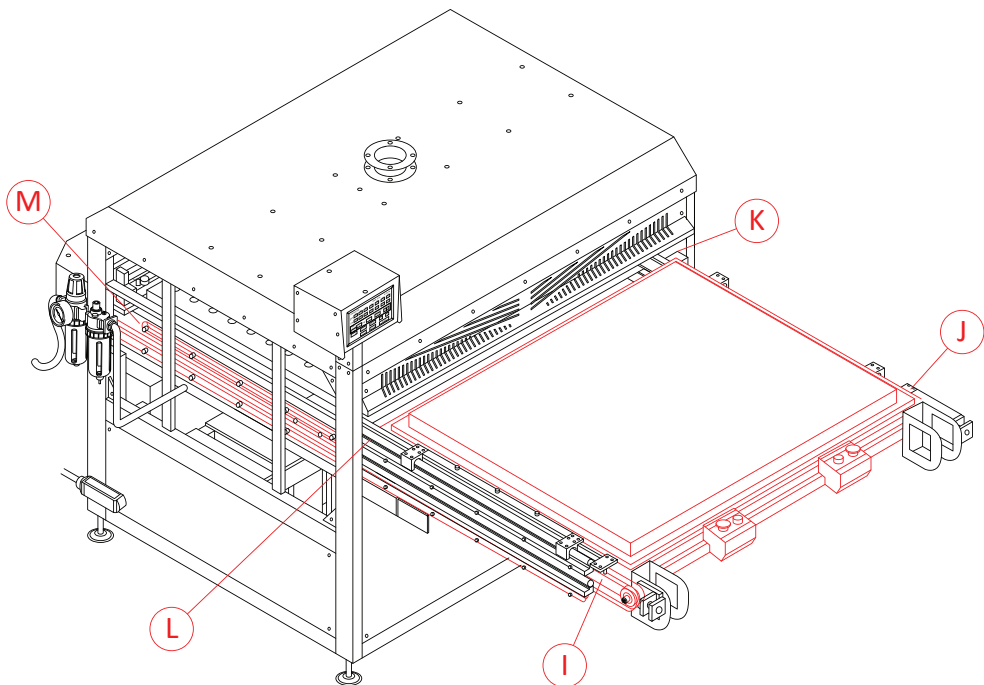

**1.2.6 Fix I, J, K, L and M connectors to the movable frame [see above].**

## Installation (Cont.)

---

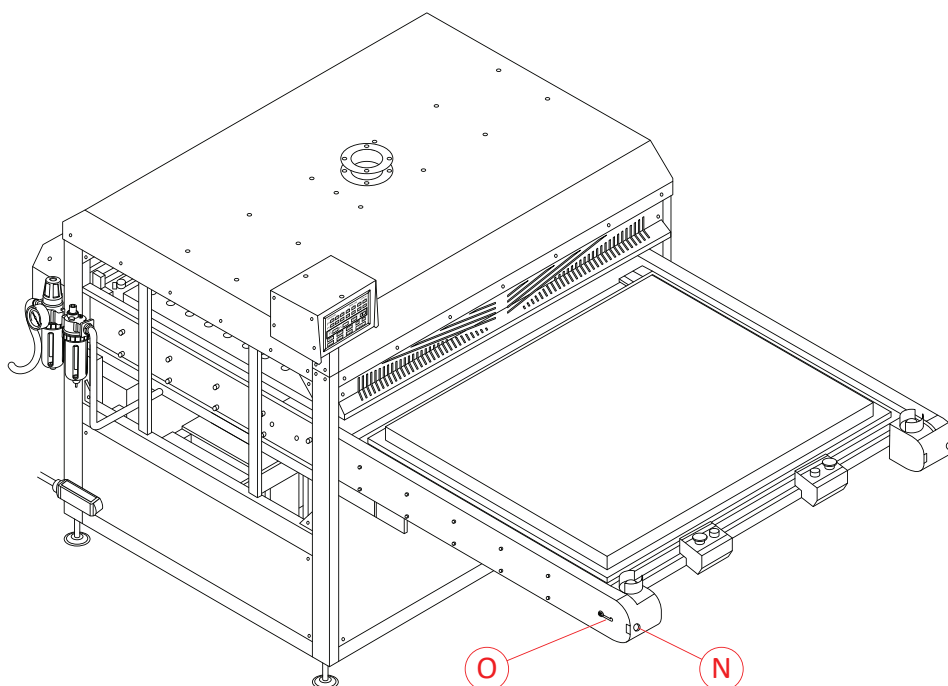

**1.2.7 To adjust tension of the synchronous belts** rotate the adjusting screw **N**. Once the desired tension is achieved lock off using the locking screw **O**.

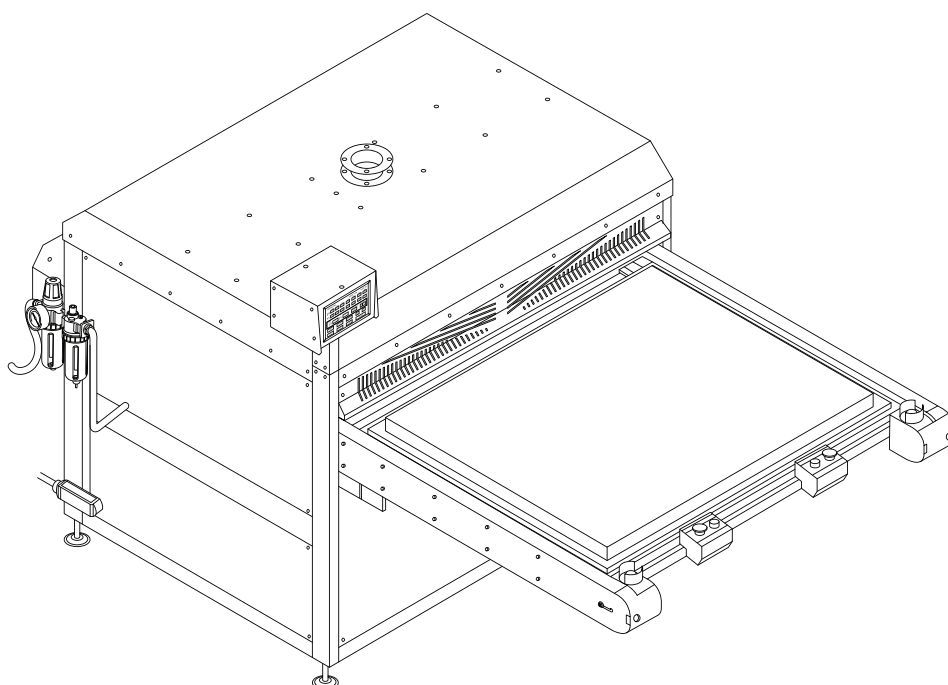

**1.2.8** Remount the left and right upper panels [see above].

**Machine assembly is now complete!**

**N.B.** Ensure adequate ventilation and then test machine functions and operations.

## 3. Maintenance and troubleshooting

---

**For good press results** it is important to keep the press surfaces clean. Wipe the surface of the heat plate with a dry non-abrasive cloth before use when the plate is cold.

**When the heat plate** is hot and not in use, keep in the open position away from the silicone pad.

### 3.1 Daily maintenance

---

**The heat plate should** be examined and cleaned on a daily basis as required.

**CAUTION:**

**Before attempting** to clean the heat plate ensure that the machine is isolated from the power supply and that the heat plate is cool.

**Note:**

It may take several hours for the heat plate to cool to handling temperature.

**It is recommended to power off the machine for 1–2 hours after approx. 6-8 hours of continuous operation.**

### 3.2 Weekly maintenance

---

**CHECK:-**

- a) Pressing pad cover
- b) Silicone pressing pad
- c) Pressing pad base

**Replace as necessary**

**Note:**

If print quality deteriorates it may be necessary to change the silicone pressing pad and pressing pad base.

### 3.3 General maintenance

---

**The following checks should be carried out at regular intervals by a qualified and competent person:-**

- Pneumatic system for air leaks
- Pneumatic system for lubrication
- Electrical connections
- Belt tension and condition
- Mechanical moving parts

Any enquiries to: [enquiries@aadkins.com](mailto:enquiries@aadkins.com)

### 3.4 Cleaning

---

**First unplug the machine.** Clean the outside of the machine frequently with

### 3.4 Cleaning (cont.)

---

a clean, moist cloth. This may conveniently be carried out when the machine is cold.

To prevent soiling of substrate, periodic wiping of entire exterior machine, including platens, with a clean rag is recommended. If necessary, use mineral spirits for cleaning a **cold** machine. Since mineral spirits are flammable, use precautions at all times and keep away from sparks, flames or hot heat platen.

### 3.5 Troubleshooting

---

Phenomenon	Reason	Solution
1. No display on the controller panel when the machine is on and heat plates cannot be reciprocated in both Manual/ Auto modes	1. Lack of electrical power	Check the power source
	2. Fuse is burned out	Check and replace the fuse
	3. Controller is damaged	Replace the controller
	4. Reciprocating motor has failed	Replace the motor
2. No display on the controller panel when the machine is on but the heat plates can be reciprocated in both Manual/ Auto modes	1. Solid state relay is broken	Replace the solid state relay
	2. Controller is damaged	Replace the controller
	3. Temperature value was set too high	Reset the temperature after a cold reboot
	4. Temperature switch (inside heating plate) broken	Replace the temperature switch
3. Display works fine but the heat plates cannot be reciprocated in either Manual/ Auto modes	1. Motor speed controller damaged	Replace the motor speed controller
	2. The synchronisation belt is broken	Replace the synchronisation belt
	3. The synchronisation wheel sprocket slips	Tighten the synchronisation wheel sprocket
	4. The sensor is broken	Replace the sensor
4. Occasional stops during Auto mode whilst transferring	1. The limit switch is loose	Tighten the limit switch
	2. The distance between the sensor and sensor shim is too large	Adjust the distance
5. Machine will not heat	1. The solid state relay is broken	Replace the solid state relay
	2. The heat platen is broken	Replace the heat platen
	3. The sensor is broken	Replace the sensor
6. Switch trips when the machine is opened	1. The sold state relay is broken	Replace the solid state relay
	2. The heat platen is broken	Replace the heat platen
	3. Circuits go to earth	Check the circuits for leakage

### 3.6 Heat Plate temperature measurement

---

**Testing of the Heat Plate** for temperature consistency or fault condition should only be undertaken after consulting Charterhouse Holdings PLC, and then only using a wired Digital Thermometer (**\*please see note below**).



**\*Please Note:**

**The Digital Thermometer with external probe** is suitable for surface, air and immersion/penetration measurement, which is required for all Adkins heat presses.

**Laser Thermometers only measure air surfaces** which can be misleading due to currents of hot air floating on the surface of the heat plate.

## **4. Machine drawings and diagrams**

---

**On the following pages** are the schematic diagrams for the Alpha Industrial Flatbed Series 7 Transfer Press.

<b>4.1</b>	<b>General Layout</b> .....	Page 13
<b>4.2</b>	<b>PLC Controller Operation Instructions</b> .....	Page 14
<b>4.3</b>	<b>Exploded Diagrams and Parts List</b> .....	Page 16
<b>4.4</b>	<b>Electrical Diagram</b> .....	Page 19
<b>4.5</b>	<b>Pneumatic Diagram</b> .....	Page 20

## 4.1 General layout

---

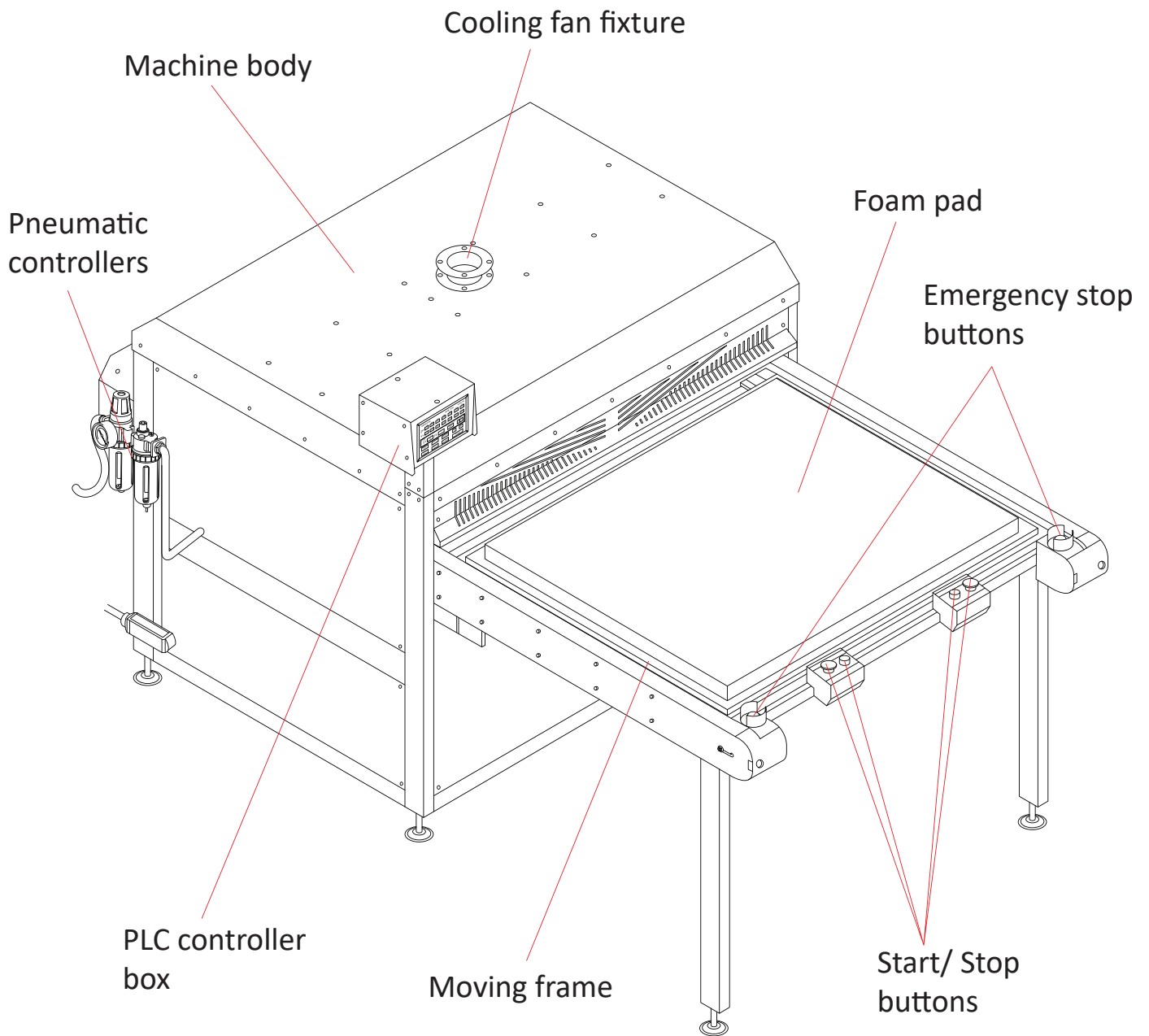

## 4.2 PLC controller operation instructions

---

### 4.2.1 Step-by-step controller operation procedure

---

- a). **Turn on the machine to display the PLC main interface:**
- The top row displays heating zones, 1# to 7# showing the actual temperature.
  - The second row displays the transfer temperature, from 1# to 7#.
  - The third row is for setting the dwell time, countdown time, press counter, and heating start and stop.
  - The fourth row indicates auto mode, semi auto mode, manual mode, °F and °C.
  - The fifth row indicates manual start, lower plate movement, upper plate movement and setup mode.

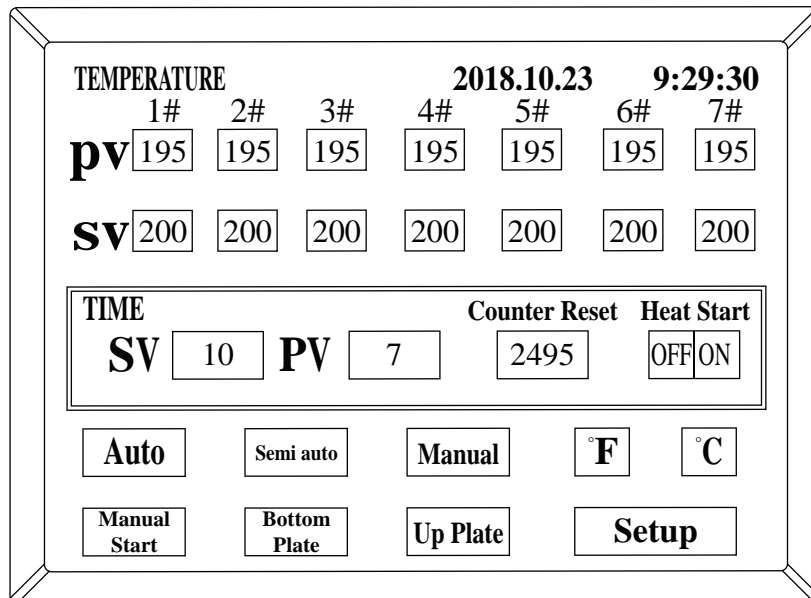

- b). **Press 1# to set the SV position,** enter the #1 to the heating zone temperature setting, press ENT to save and then exit, CLR to clear the setting, ESC to reset; The same procedure is used for setting 2# to 7#; Then press °F or °C; After setting, press ‘Heat Start’ to open the heating switch, the machine will enter into heating mode. (Adjustable temperature range is 50 - 225°C (50 - 437°F), adjustable time range is 0 - 999 sec)
- c). **When the set temperature is achieved,** press the ‘Manual’ button to enter operation mode, then press the ‘Bottom Plate’ button until it reaches the lower limit and stops. Then press the ‘Manual Start’ button to begin the heat transfer cycle and countdown cycle. When the countdown reaches three seconds to go, the buzzer will sound for one second, the upper platen will then return to the upper limit and the heat transfer cycle will be complete.

## PLC controller operation instructions (Cont.)

- d). **When the lower platen has moved to the lower limit** or when the upper platen has moved to the upper limit, press the 'Semi auto' button, the machine will then enter into semi auto mode (single transfer mode).
- e). **When the bottom platen has moved to the lower limit** or when the upper platen move to the upper limit, press the 'Auto open' button the machine will enter into auto mode (mutiple transfer mode). For operation procedure please refer to step c).
- f). **Press the 'Reset' button** and the counter value will flash and return to 0.
- g). **When one or more thermocouples are malfunctioning** 'Abnormal' appears between the current temperature and the set temperature [see below], and the heating is turned off.

<b>pv</b>	1# 195	2# 195	3# 195	4# 195	5# 195	6# 195	7# 195
<b>sv</b>	200	200	200	200	200	200	200

Abnormal

- h). **Pressing 'Setup' enters into machine engineering mode.**
- The top row displays heating zones, 1# to 7# showing the actual temperature.
  - The second row shows temperature calibration values 1# to 7#, the calibration range is -99 to +99; Please contact Adkins Technical Support for guidance when updating settings in the above mode.

**Setup**

<b>pv</b>	1# 195	2# 195	3# 195	4# 195	5# 195	6# 195	7# 195
<b>Compensate</b>							
	-5	-5	-5	0	3	3	0
<b>Operation range</b>				<b>Counter Reset Heat Start</b>			
	5	5	5	5	5	5	5
<b>Tray in place delay</b>		<b>Floor rise time</b>		<b>Delayed operation</b>			
1.0		1.0		1.0		Return	

# 4.3 Exploded diagrams and parts list

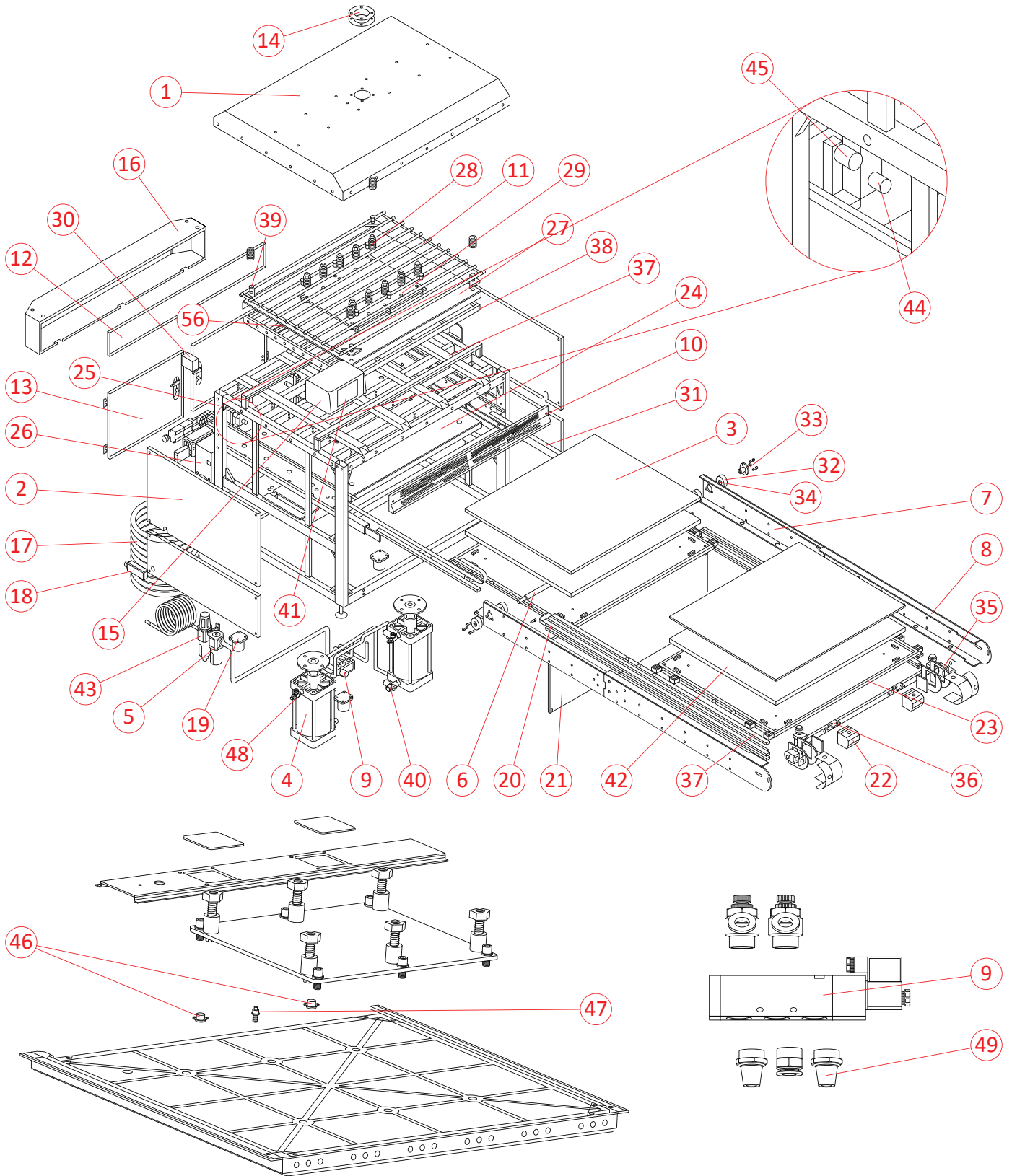

## Exploded diagrams and parts list (Cont.)

### Control panel

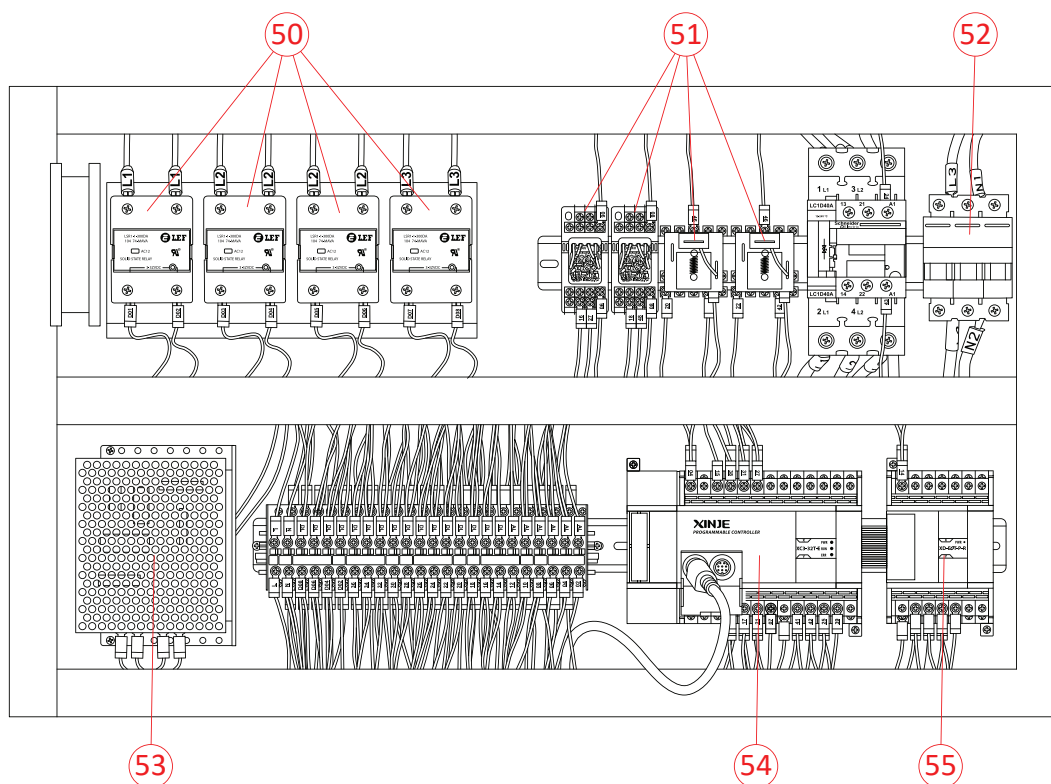

No.	PartsDescription	Qty.	Part No.
1	Top cover plate	1	-
2	Side plate	2	-
3	Black silicone pad - 100cm x 120cm	4	AIP/SIL100X120
4	Air cylinder	4	-
5	Air system lubricator	1	-
6	Drive rod	1	-
7	Rear rail fixing plate	2	-
8	Front rail fixing plate	2	-
9	Solenoid valve	2	-
10	Front plate	1	-
11	Iron pipe	12	-
12	Back plate	1	-
13	Electric box	2	-
14	Fixture for cooling fan	1	-
15	Electric box	1	-
16	Shield for drive shaft	1	-
17	Power cord	1	-
18	Unite box	1	-
19	Caster	4	-
20	Slide rail	4	-
21	Fallboard for the frame	1	-

### Exploded diagrams and parts list (Cont.)

---

22	Start control box	2	-
23	Moving frame	2	-
24	Lifting board	1	-
25	Machine frame	1	-
26	Lower electric control box	1	-
27	Cover plate for heat platen	1	-
28	Fixing bolt	6	-
29	Upper adaptor plate	1	-
30	Governor	1	-
31	Synchronous belt	4	-
32	Synchronizing wheel	4	-
33	Fixed flange	2	-
34	Gear	1	-
35	Emergency stop button	2	-
36	Start button	2	-
37	Slide block	8	-
38	Heat plater	1	-
39	Shim plate for heat plater	4	-
40	Tee piece	3	-
41	PLC Display	1	-
42	Foam pad - 100cm x 120cm (30mm thick)	2	AIP7FOAM100X120
43	Air flow filter/ regulator	1	-
44	Proximity switch	1	-
45	Silicone stop	2	-
46	16 mm Fixules nut	12	-
47	16 mm Threaded bar	4	-
48	Pneumatic restrictor	4	-
49	Pneumatic silencer	2	-
50	Solid state relay	1	-
51	Relays	4	-
52	Circuit breaker (MCB)	1	-
53	PLC power supply	1	-
54	PLC controller board	1	-
55	PLC external controller board	1	-
56	Thermal Cut-Out	1	BM338

# 4.4 Electrical diagram

## 380V 3-Phase

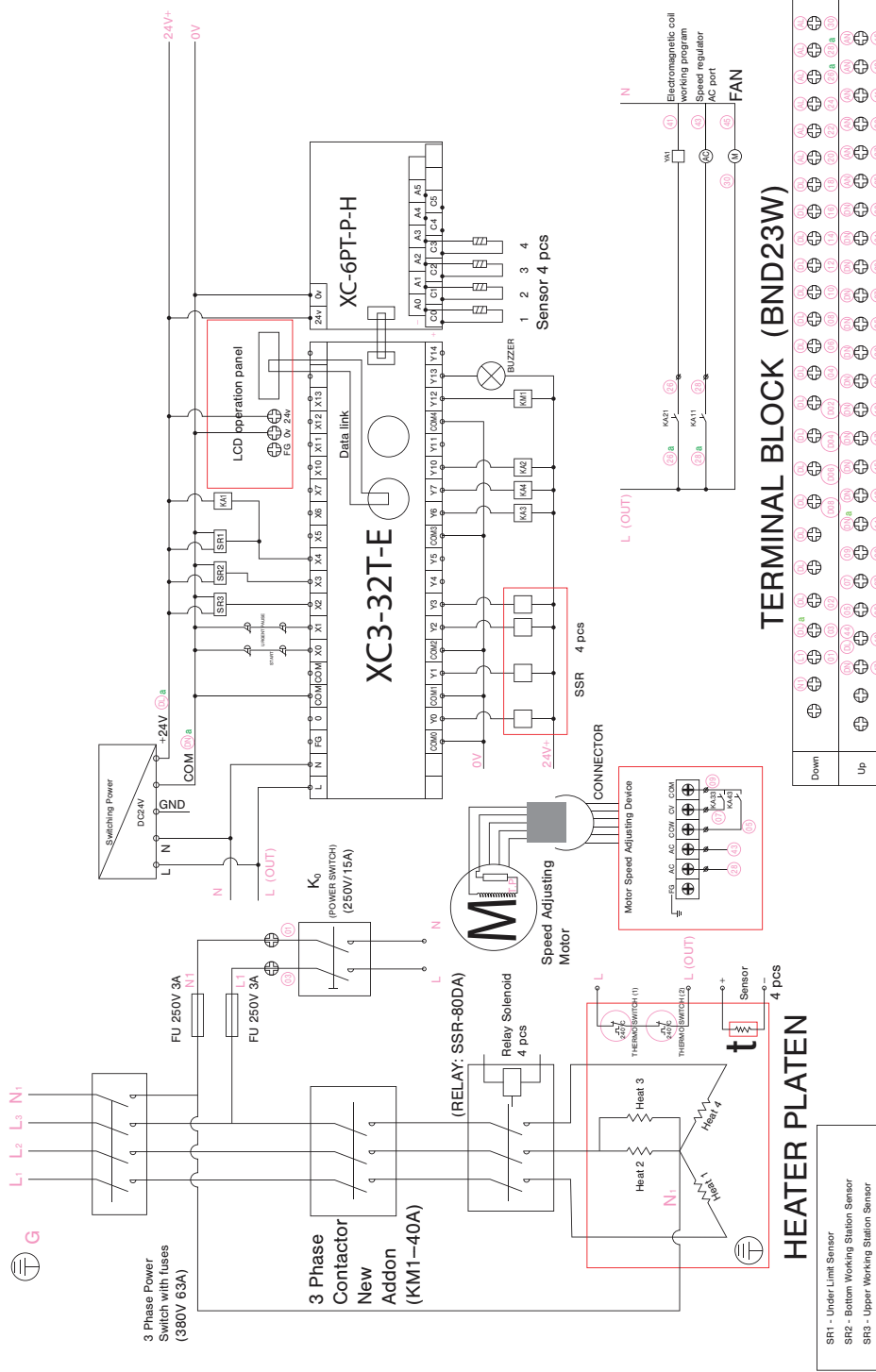

## 4.5 Pneumatic diagram

---

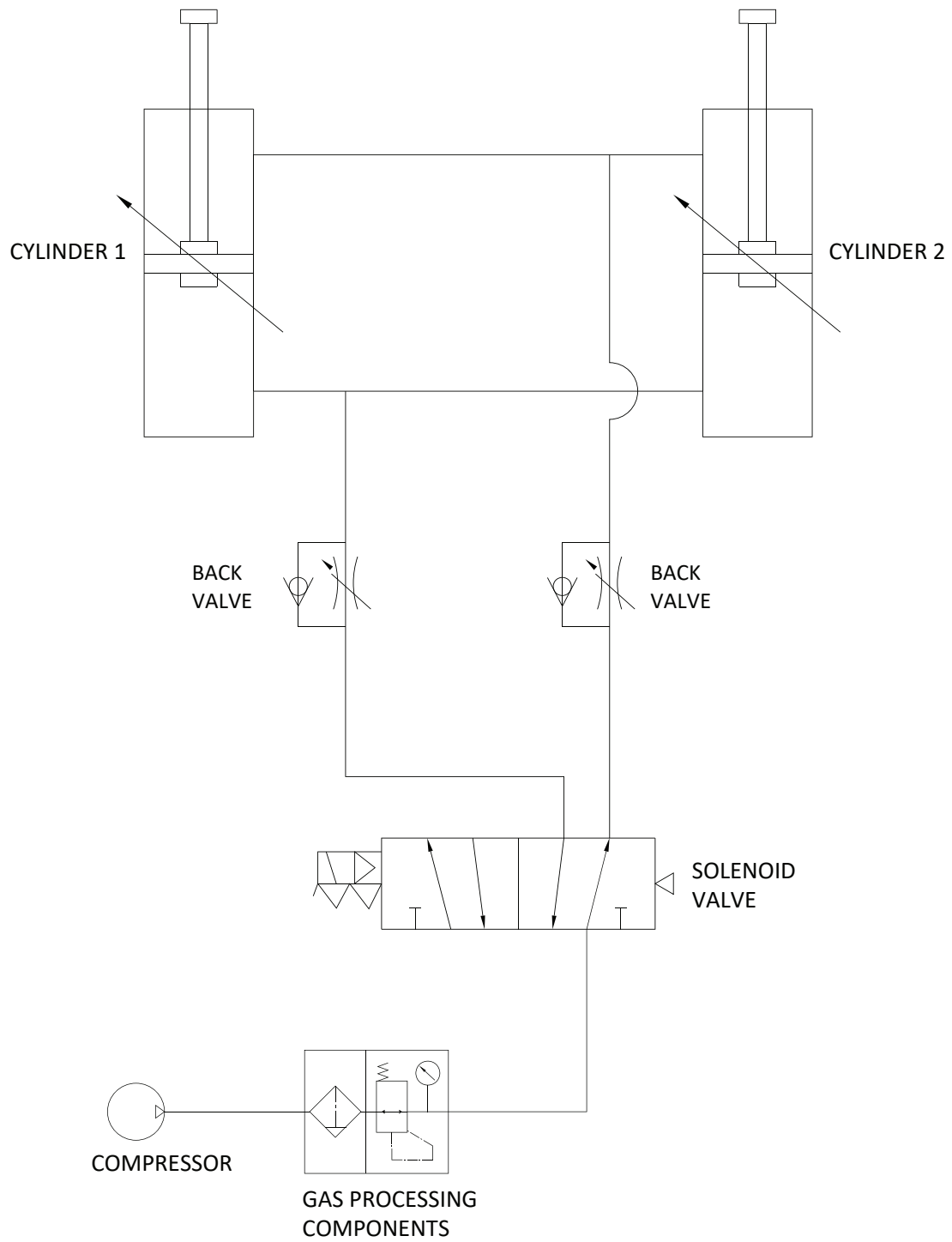

## 5. Design change

---

**With the policy of constant improvement and/or modification** to meet changing conditions, the right is reserved to change the design and/or specifications at any time without prior notification, and therefore specifications may vary and not be in accordance with this manual.

## 6. Guarantee (limited warranty)

---

**Charterhouse Holdings PLC** warrants that the press is free from defects in material and workmanship (excluding Pressing Pad Assembly) for a period of 12 months from the date of supply. The machine comes with a 12 month warranty on the heating element, one year warranty on parts and 90 days labour.

This warranty covers all parts to repair the defects, except when damage results from misuse or abuse, accident, alteration or negligence or when a machine has been improperly installed.

If a press covered by warranty should need to be returned to the factory for examination and repair, if on-site component replacement is not possible, **Charterhouse Holdings PLC** will make every effort to repair the customers press. The warranty will only be effective when **Charterhouse Holdings PLC** author-ises the original purchaser to return the machine to the factory and only when the product upon examination has proven to be defective.

Should in our opinion any part of this press be defective in materials or workmanship, it will be replaced or repaired free of charge, provided that the press has been installed and operated in the correct manner and not subjected to misuse. If **Charterhouse Holdings PLC** authorise a replacement press, the warranty of the replacement press shall expire on the anniversary date of the original machines invoice to the customer.

In order for this warranty to be effective, no return of machine or parts may be made without prior factory authorisation. (This will exclude any travelling and/or carriage costs which will be charged at our discretion).



This is the sole warranty given by the company; there are no warranties, which extend beyond the description on the face hereof. The seller disclaims any implied warranty of merchantability and/or any implied warranty of fitness for a particular purpose; the buyer agrees that the goods are sold “as is”. **Charterhouse Holdings PLC** does not warrant that the functions of the press will meet the customer’s requirements or expectations. The entire risk as to use, quality and performance of the press lies with the customer. (No claim of any kind shall be greater than the sale price of the product or part to which the claim is made).

In no event will **Charterhouse Holdings PLC** be liable for any injury, loss or damage, including loss of profits, destruction of goods or any special, incidental, consequential or indirect damages arising from the use of the press or accompanying materials. This limitation will apply even if **Charterhouse Holdings PLC** or its authorised agent had been advised of the possibility of such damage.



HEAT PRESS TECHNOLOGY

# A. ADKINS AND SONS LIMITED DECLARATION OF CONFORMITY

Application of Council Directives:	European Low Voltage Directive ( <b>LVD</b> ), European Machinery Directive ( <b>MD</b> ), Electro Magnetic Conformity ( <b>EMC</b> )
Standards to which Conformity is Declared:	<b>(LVD): EN 60204-1:2018</b> <b>(MD): EN ISO 12100:2010 2006/42/EC Annex1</b> <b>(EMC): EN 61000-6-2:2019</b>
Manufacturer's Name:	<b><u>Charterhouse Holdings Plc</u></b>
Manufacturer's Address:	Oakridge Park, Trent Lane, Castle Donington, Derby DE74 2PY United Kingdom.
Type of Equipment:	Alpha Industrial Flatbed Series 7 (100 cm x 120 cm)
Standards Compliance:	 
Model Number:	<u>AIPRT120</u>
Serial Number:	.....
Year of Manufacture:	.....

I, the undersigned, hereby declare that the equipment specified above conforms to the above directives and standards.

Place: Castle Donington, United Kingdom

Signature: *M. S. Carter*

Date: 15th June 2023

Full Name: Miles Carter  
Position: Chief Executive